

opk Hidden Door W 55 kg

INTEGRIERTES SCHIENEN DESIGN.
BUILT-IN TRACK DESIGN.
CONCEPTION DE PISTE INTÉGRÉE.

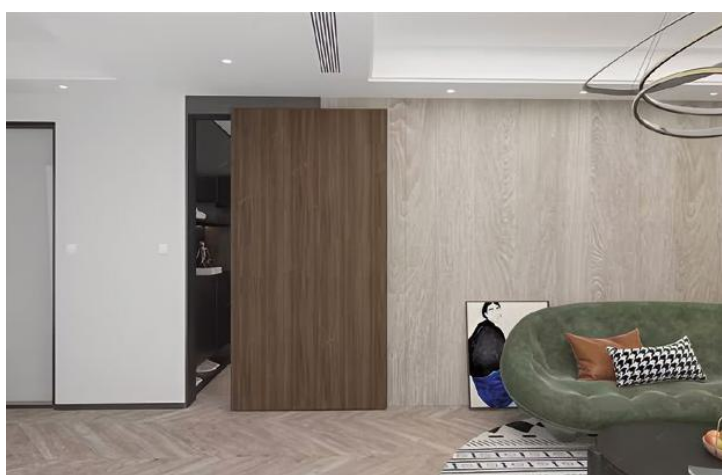
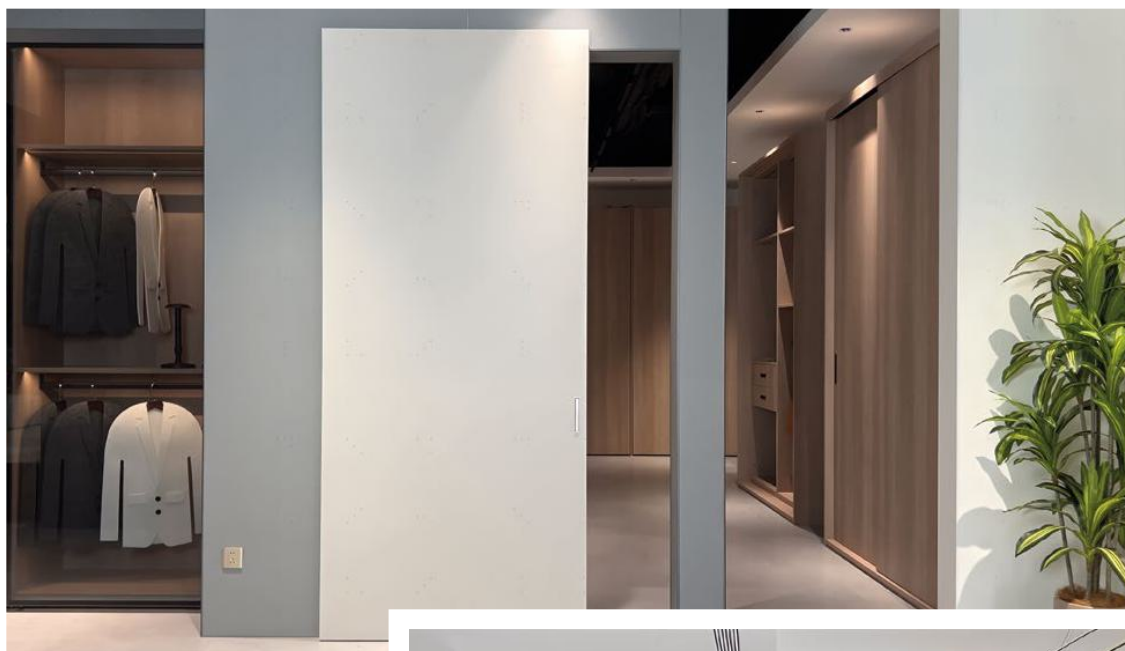

Bausysteme
Building systems /
Systèmes de construction

opk Hidden Door W 55 kg

Boden- Deckenmontage untenlaufend

Floor- Ceiling Mounting Bottom Running /

Montage au étage au plafond en bas



Technische Zeichnung

Technical drawing /
Plans et schémas

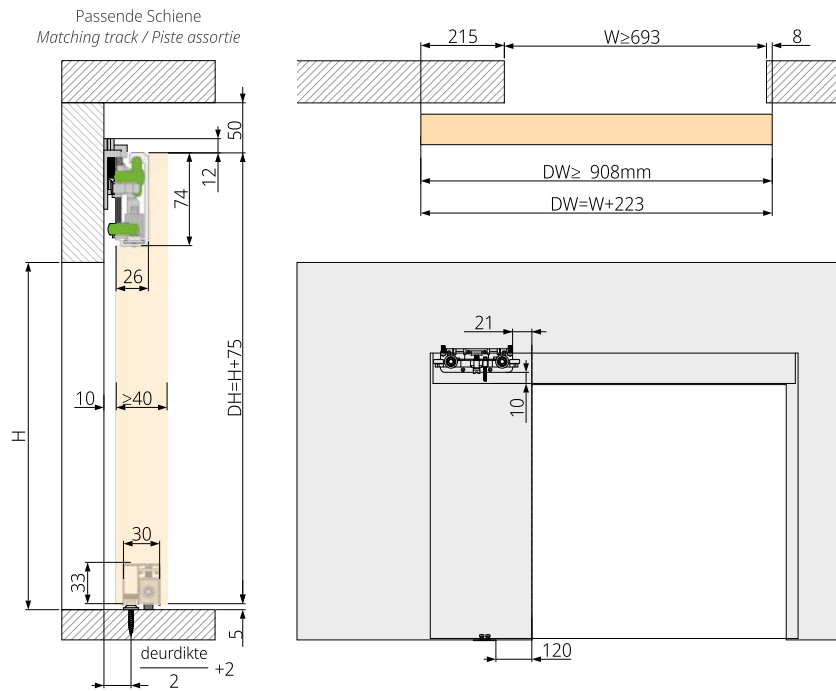

Türschlitzmaße. Mit Schienenabdeckung
Door slot dimensions. With the track cover
Dimensions de la fente de porte.
Avec le cache-rail

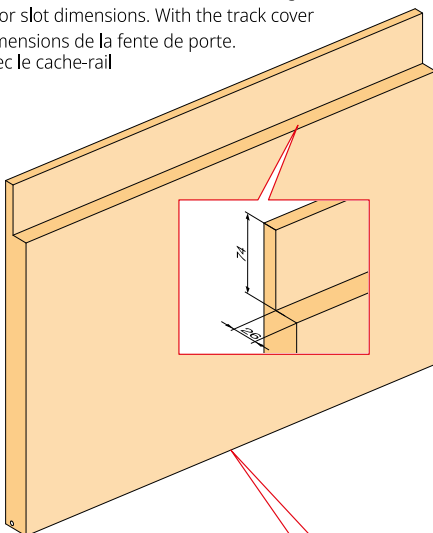

Türschlitzmaße. Ohne Schienenabdeckung
Door slot dimensions. Without the track cover
Dimensions de la fente de porte.
Sans le cache-rail

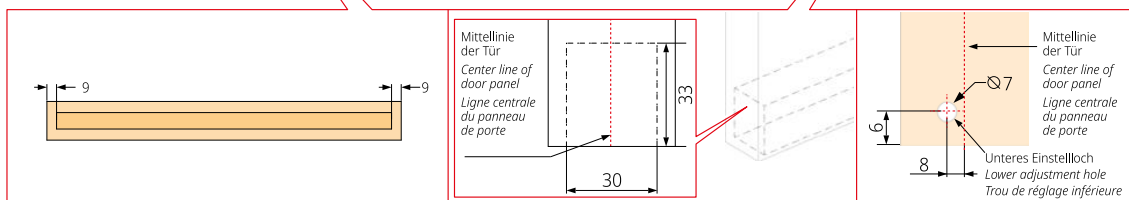
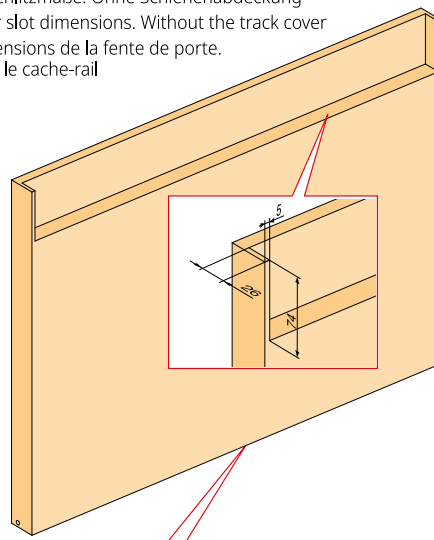

opk Hidden Door W 55 kg

Boden- Deckenmontage untenlaufend

Floor- Ceiling Mounting Bottom Running /
Montage au étage au plafond en bas



Art.-Nr. /
No. / N° d'art.

		≤60	≤1.5 m	-	05-000-100-001
--	--	-----	--------	---	----------------

Konfiguration für 1 Tür

Configuration for 1 door left / Configuration pour 1 porte à gauche

Alles drin!
All inclusive!
Tout compris!



Obere Laufwerk der Tür <i>The top wheel of Invisible door / La roue supérieure de la porte invisible</i>		1
Kollisionsschutz <i>Invisible door (Anti-collision) / Porte invisible (Anti-collision)</i>		2
Untere Laufwerk der Tür <i>Bottom Sliding Roller / Rouleau coulissant inférieur</i>		2
Untere Führung <i>Bottom guide wheel / Roue de guidage inférieure</i>		2
Rückwärtsdämpfer <i>Reverse damper / Amortisseur de marche arrière</i>		2
Obere Laufschiene <i>Top track / Rail supérieure</i>		1
Untere Laufschiene <i>Bottom track / Rail inférieure</i>		1
Blende (rechts) <i>Decorative door cover (right) / Revêtement de porte décoratif (droite)</i>		1
Blende (links) <i>Decorative door cover (left) / Revêtement de porte décoratif (gauche)</i>		1